

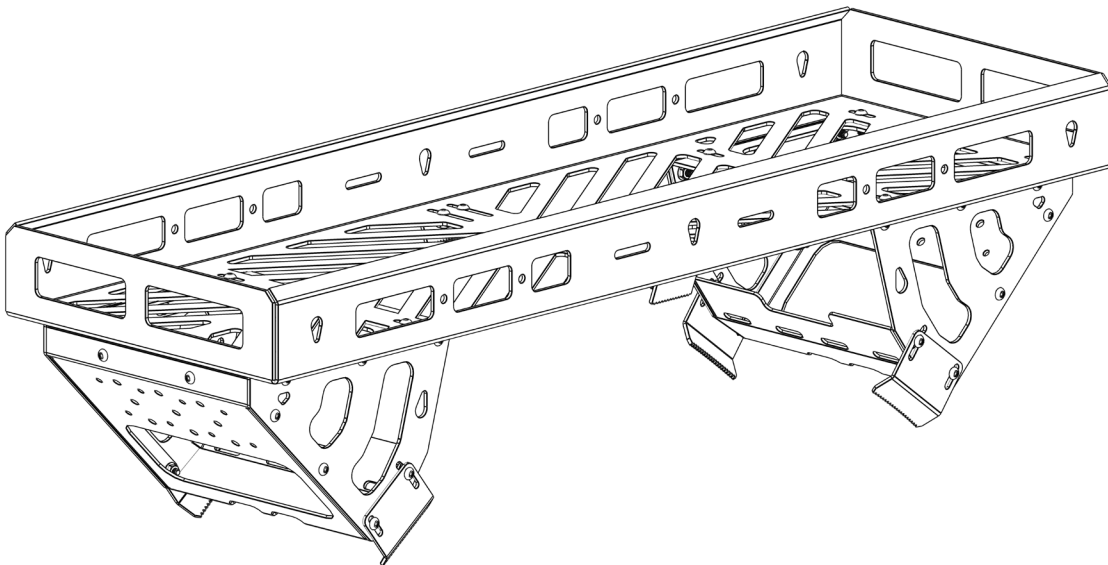

VICTORY 4X4

UNIVERSAL SPARE TIRE BASKET

INSTALL INSTRUCTIONS



Please read the mounting instructions below carefully before attempting to install.

Be sure to check out the install video on the product page, if available.

Thank you for purchasing from Victory 4x4! Checkout our website, victory4x4.com for other great off-road products. Be sure to rate and review our product online. If you have any questions or are missing parts, please don't hesitate to call us at 269-459-8447!

INCLUDED HARDWARE

48x

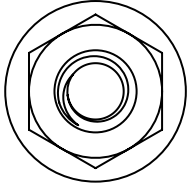

1/4"-20
Serr. Flange Nut

48x

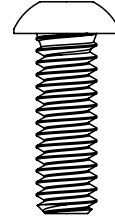

1/4"-20 X 3/4"
Button Head

48x

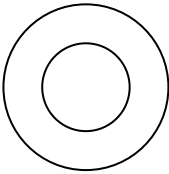

1/4" ID
Washer

1x

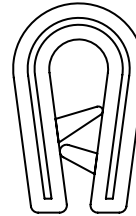

18" strip
U Channel Edge Trim

INCLUDED PARTS

1x

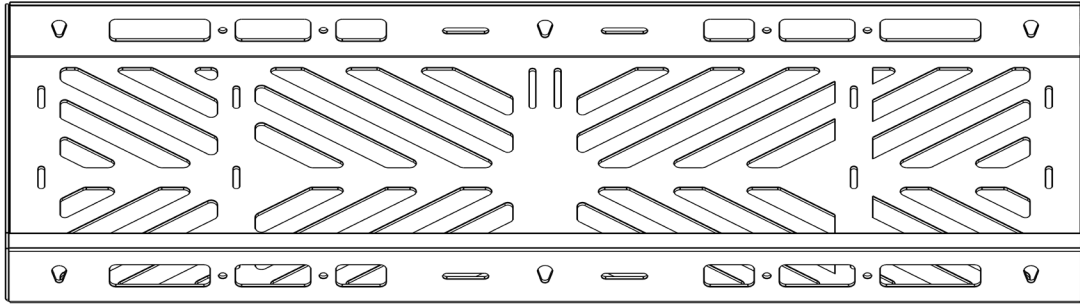

2x

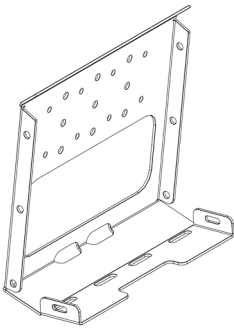

2x

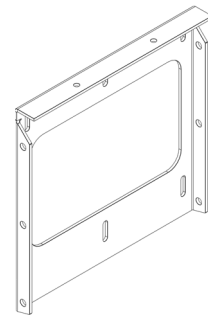

4x

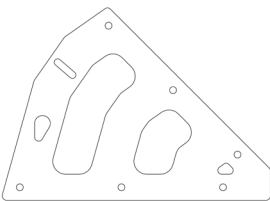

4x



2x



INSTALLATION

- 1 Start by assembling the legs of the basket. First, mount the side panels to the center panel using the provided hardware through the top two holes. Then, mount the top panel between the sides and center panel. Make sure the top panel is inside of the others. Leave the bolts slightly loose until they are all in. Then tighten them all fully.

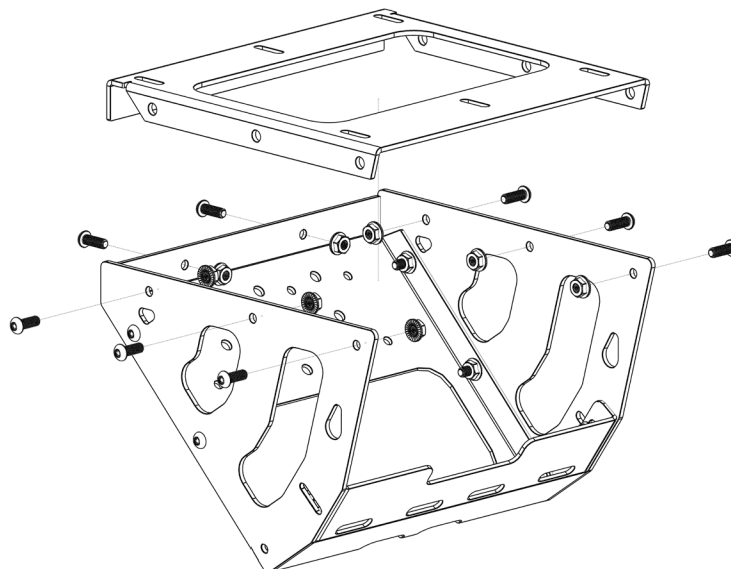
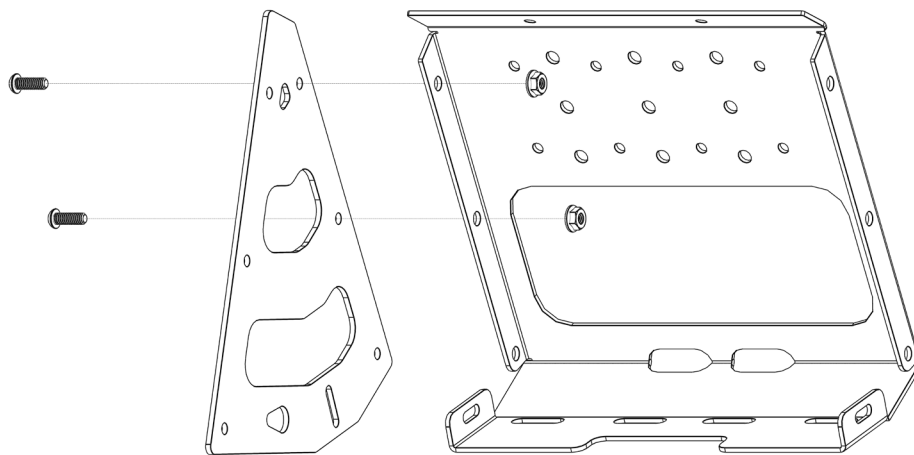

INSTALLATION

- 2** With the legs assembled, mount them to the basket using the provided hardware. The six slots on each side of the basket line up with the six slots in the top of each leg. The side with the bolt patterns faces outward.

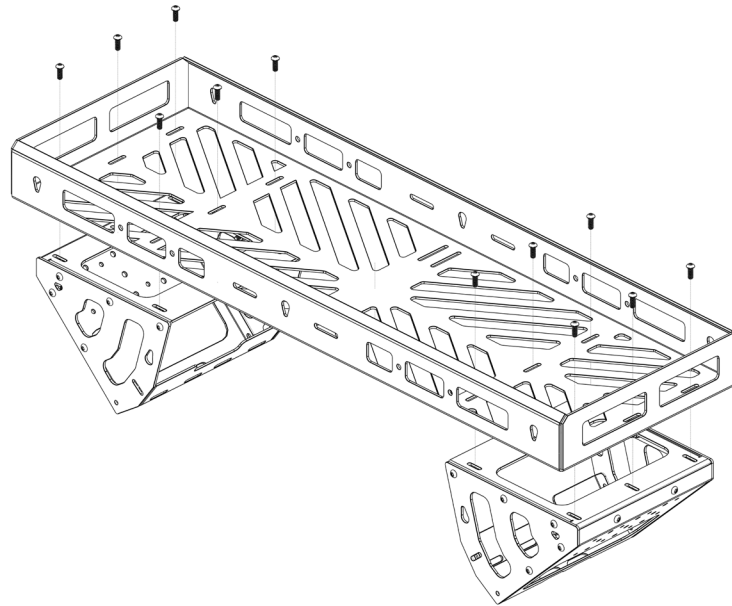

- 3** Next, loosely install the lower brackets into the hole and slot in the bottom of the legs. These brackets should bend in beneath the legs.

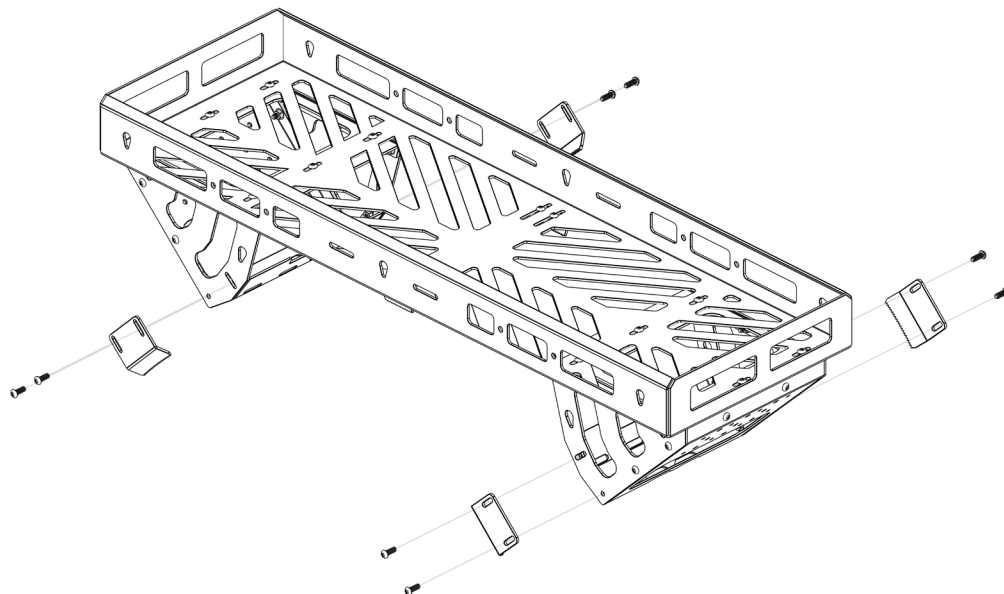

INSTALLATION

- 4 Next, set the basket up onto your spare tire in order to see how far in or out the legs of the basket need to be positioned. If you want the basket to sit tight to the tire when installed, position the legs so that the basket sits around 1/4" above the tire. If you have a third brake light in the way and need the basket to sit above it, position the legs so that the basket sits 1/4"-1/2" above the light. If you can't push the legs in far enough for that much of a gap, just set them to the narrowest position possible. Once they are centered and a good distance apart, tighten them into place and pull the basket off the tire.

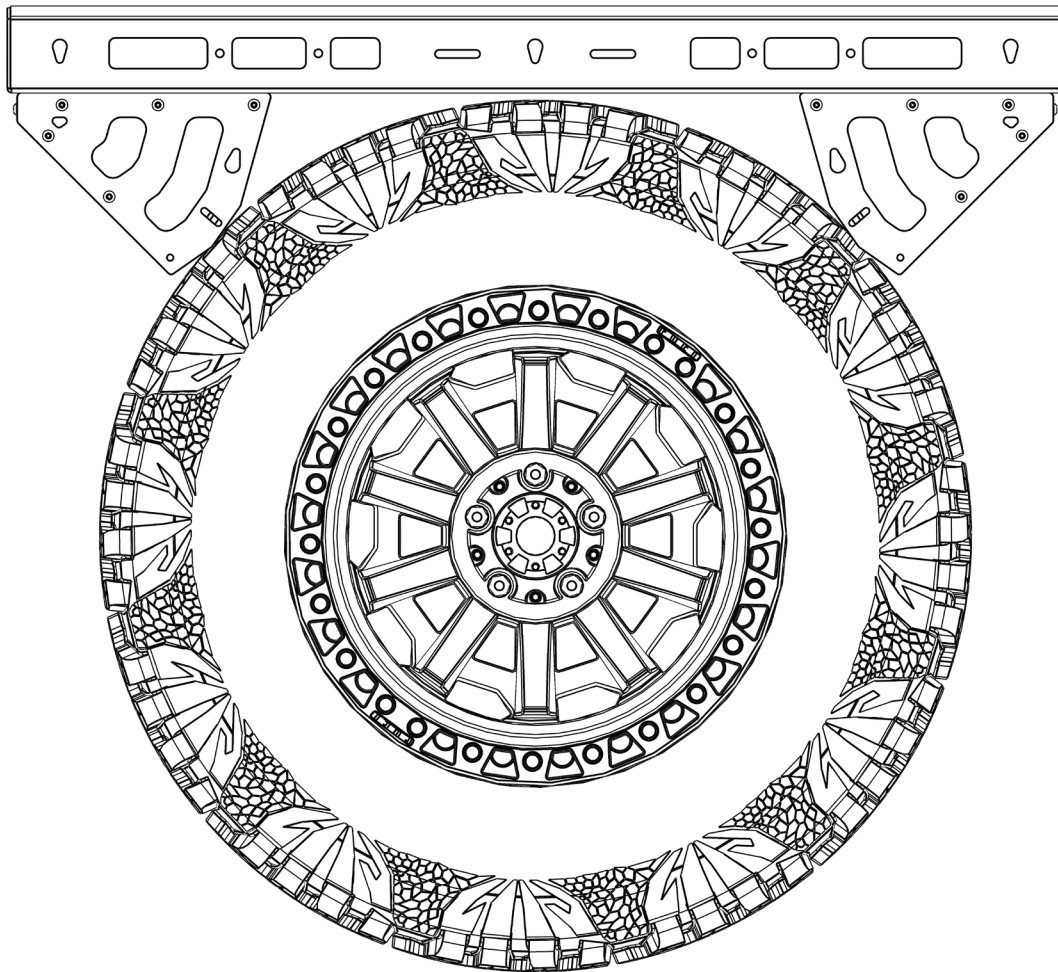

INSTALLATION

- 5** Next, if your third brake light is in a position where it won't affect the basket at all, loosely bolt the small top brackets to the bottom of the basket as shown below. If your brake light sits over the top of the tire or somewhere that will be covered by the basket, you do not need these brackets because your basket will have to sit above the light.

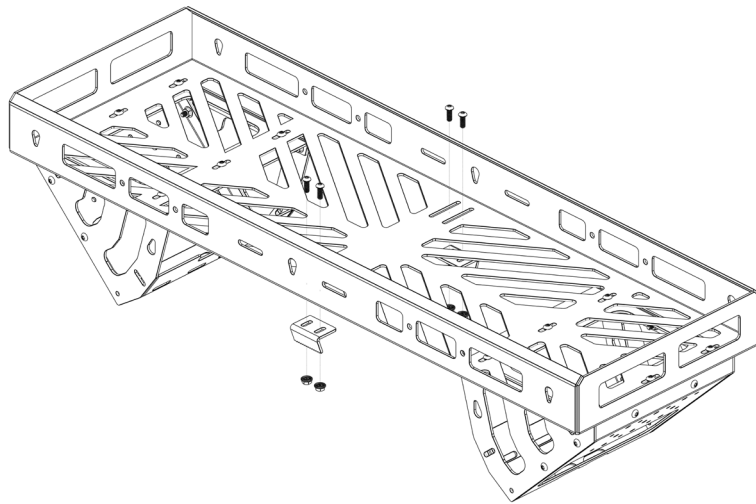

- 6** Next, loosely install the lower brackets into the hole and slot in the bottom of the legs. These brackets should bend in beneath the legs.

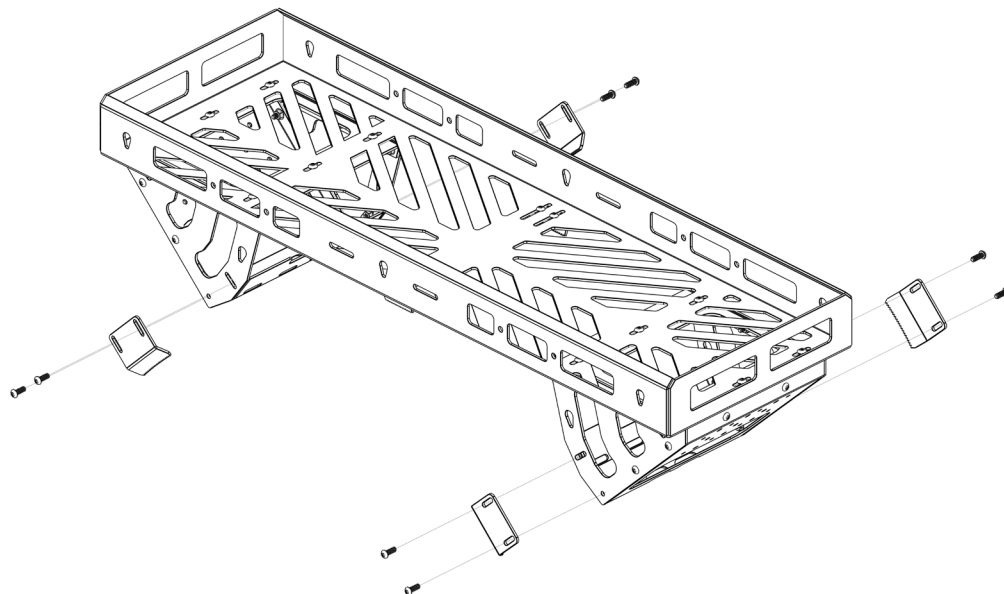

INSTALLATION

- 7** If you do not have an interfering third brake light, skip to step 8. If you do, set the basket back up onto the tire and position the basket so it is above the light as mentioned before. Once it is, tighten the lower brackets into position. Depending on the size of your tire and brake light, you may need to lift the basket off the tire and use the lower brackets as the feet. When tightening the brackets, make sure the teeth dig into the side of the tire a bit, so they act as feet while also preventing rotation. Once the basket is in position, hook the ratchet strap to the slots in the bottom of the center panel and route it beneath the tire. Then, tighten the basket to the tire. Skip to step 9.
- 8** Set the basket up onto your tire and center it. Then, move the upper brackets in until they touch the outside surfaces of the tire and tighten them. Once you have done that, hook the ratchet strap to the slots in the bottom of the center panel and route it beneath the tire. Then, tighten the basket to the tire. Once it is tightened enough that the basket is touching the top of the tire, position the lower brackets so that the teeth are on the edge of the tire and tighten them into place. If all of this is done correctly, the teeth in the upper and lower brackets should be slightly digging into the sides of the tire. It is best to position the brackets in places where you can tighten them without bending them much, but where they are still able to dig in.

INSTALLATION

- 9** Once everything is tightened and the basket is secure on the tire, hook one end of a cinch strap to the hook point in the front of the basket leg and then route it through one of the gaps between spokes in your wheel. Then, hook the other side to the hook point in the back of the leg. Do the same on the other side and then pull each tight.
- 10** Next, make sure everything is tight and secure and pull on the basket a few times to make sure there is no movement of the basket relative to the tire. Once you achieve that, hide the leftover on each strap however you would like to.
- 11** The final, optional step is to install rubber trim into the corners of the basket. If you would like to do so, simply cut four 2-3" strips from the provided trim and push them onto the edges of the sides as shown below.

