

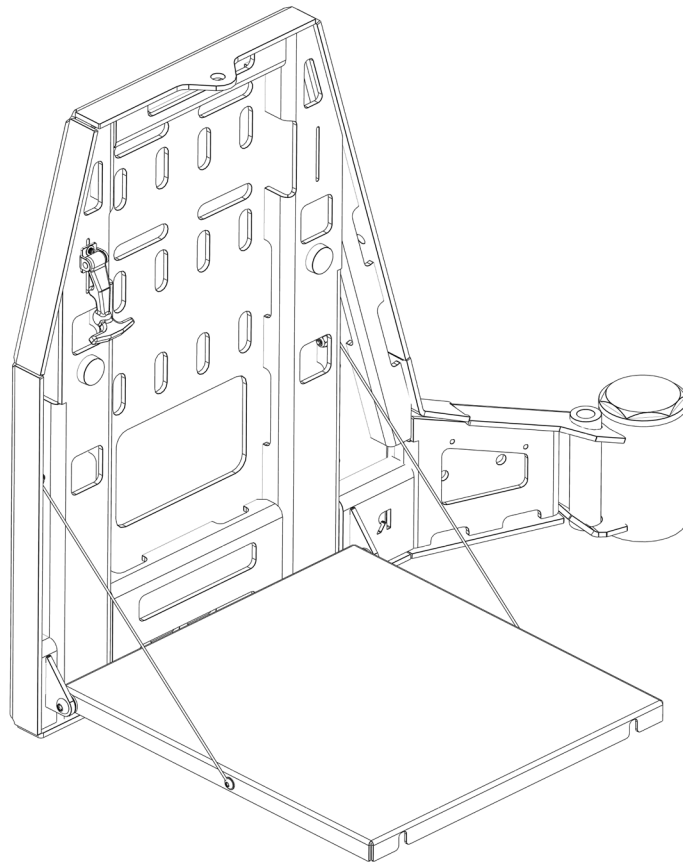

VICTORY 4X4

UNIVERSAL ADVENTURE CARRIER FOLD DOWN TABLE

INSTALL INSTRUCTIONS



Please read the assembly instructions below carefully before attempting to install.

Be sure to check out the install video on the product page, if available.

Thank you for purchasing from Victory 4x4! Checkout our website, victory4x4.com for other great off-road products. Be sure to rate and review our product online. If you have any questions or are missing parts, please don't hesitate to call us at 269-459-8447!

INCLUDED HARDWARE

2x



5/16"-18 X 3/4"
Button Head

4x

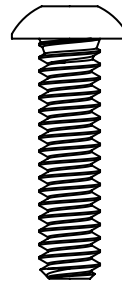

10-24 X 3/4"
Button Head

2x



5-40 X 1/2"
Socket Head

2x

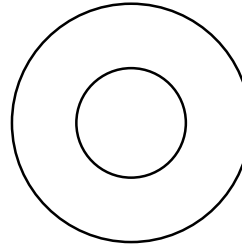

5/16"
Nylon Plastic Washer

4x

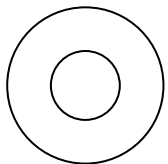

#10
Nylon Plastic Washer

2x

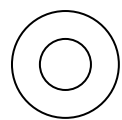

M4
Flat Washer

2x

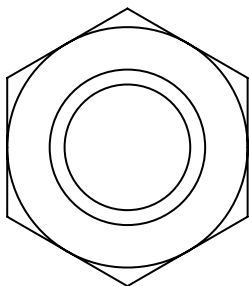

5/16"-18
Nylon Lock Nut

4x

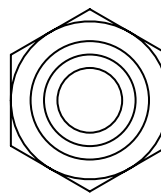

10-24
Nylon Lock Nut

2x

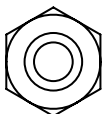

5-40
Nylon Lock Nut

2x

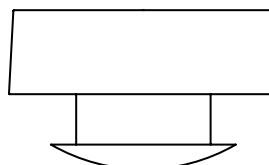

Rubber Push-in
Bumper

INCLUDED PARTS

1x

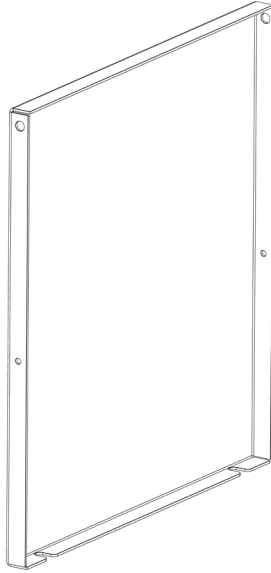

1x

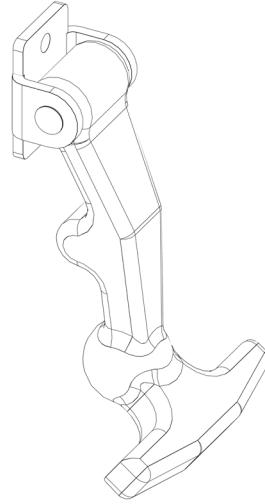

2x



ASSEMBLY

- 1** Start by inserting the two rubber push-in bumpers into the large holes in the vertical bars on the inside of the adventure carrier.

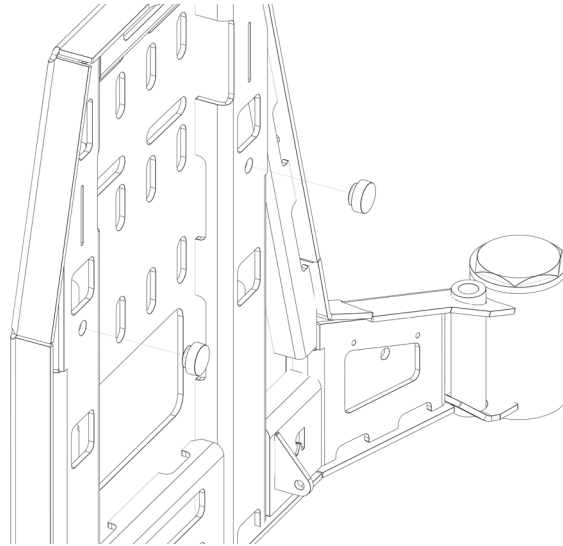

- 2** Next, mount the table onto the inside of your carrier. Place the table between the two tabs on the bottom of the carrier and slide a 5/16"-18 X 3/4" button head bolt through each side making sure to sandwich a 5/16" plastic washer between the tab on the carrier and the side of the table. Then, fasten it into place with the 5/16"-18 lock nut. You want to tighten it enough that the table can't wiggle while still being able to flip up and down. Also, make sure you bolt the table on in the correct orientation so that the flat side is facing up when the table is down.

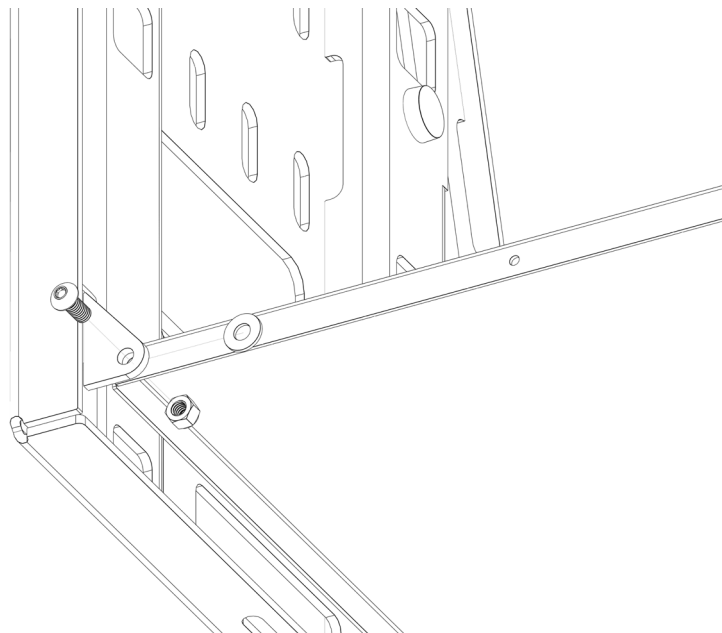

ASSEMBLY

- 3** Next, attach the lanyards to the table using the 10-24 X 3/4" button head bolts, #10 plastic washers and 10-24 nylon lock nuts. The washers should go between the flat side of the eye of the lanyards and the sides of the table.

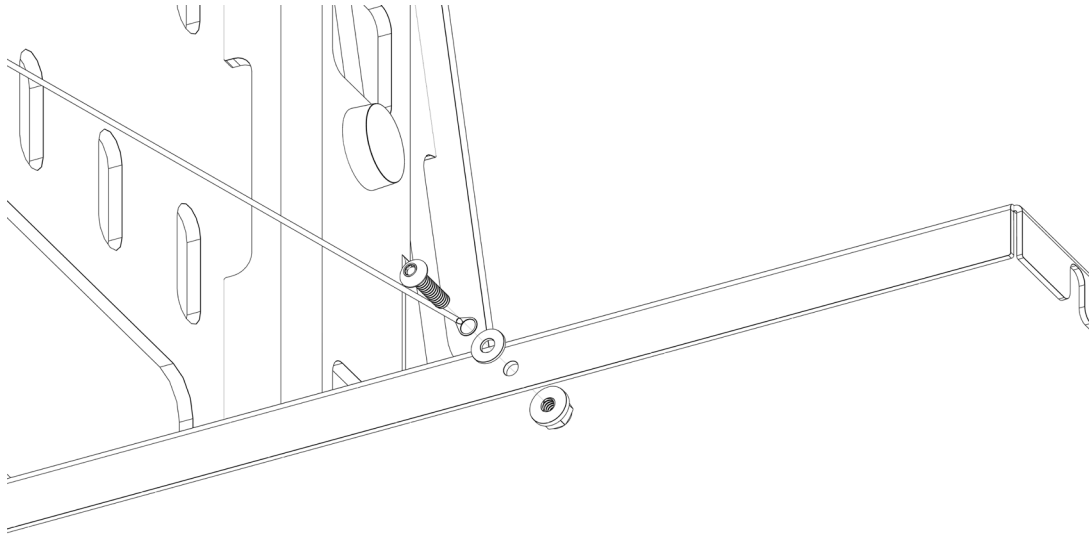

- 4** Next, attach the lanyards to the holes in the outside of the vertical bars that are on the inside of the carrier using the same hardware as the last step. The washers should again go between the flat side of the eye of the lanyards and the sides of the bars.

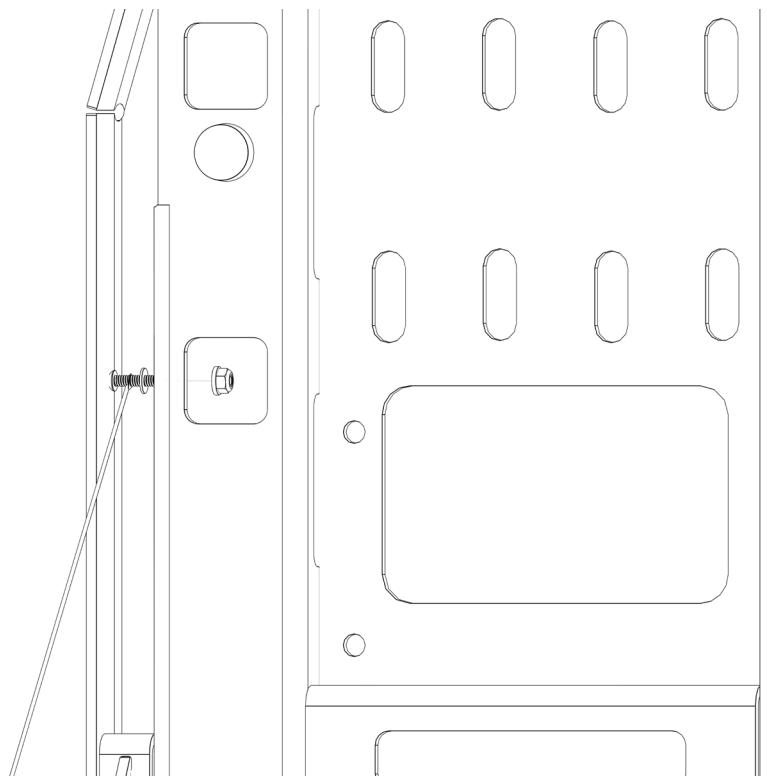

ASSEMBLY

- 5** Finally, mount the latch to the slot on one of the vertical bars on the inside of the carrier. It can go in either one but depending on your vehicle, one side may work better than the other. To mount the latch, use the 5-40 X 1/2" socket head screws with M4 flat washers on the outside of the latch and then slip the 5-40 lock nuts onto the backside through the cutout in the side of the bar. It is easiest to loosely tighten it into place first and then move it around until you find the best position for it. Once it is in position, tighten it fully into place. It should be far enough up in the slot that you must stretch the rubber latch a bit in order to latch it to the table.

