



VICTORY  
4X4

# TUNDRA GAS TANK SKID (26G) INSTALLATION INSTRUCTIONS

## TOOLS NEEDED

- 5/16" allen

## HARDWARE

- 1/2-13 x 1" Button Head qty. 8
- 1/2-13 x 1 1/2" Hex Head qty. 3
- 1/2-13 Flange Nut qty. 11
- 3/8-16 x 1" Button Head qty. 1
- 3/8-16 Flange Nut qty. 1
- 7/16 Flat Washers qty. 3

Please read the instructions below carefully before attempting to install.

1. First we will install the brackets to the skid so we can mark the 2 holes to be drilled in the frame.

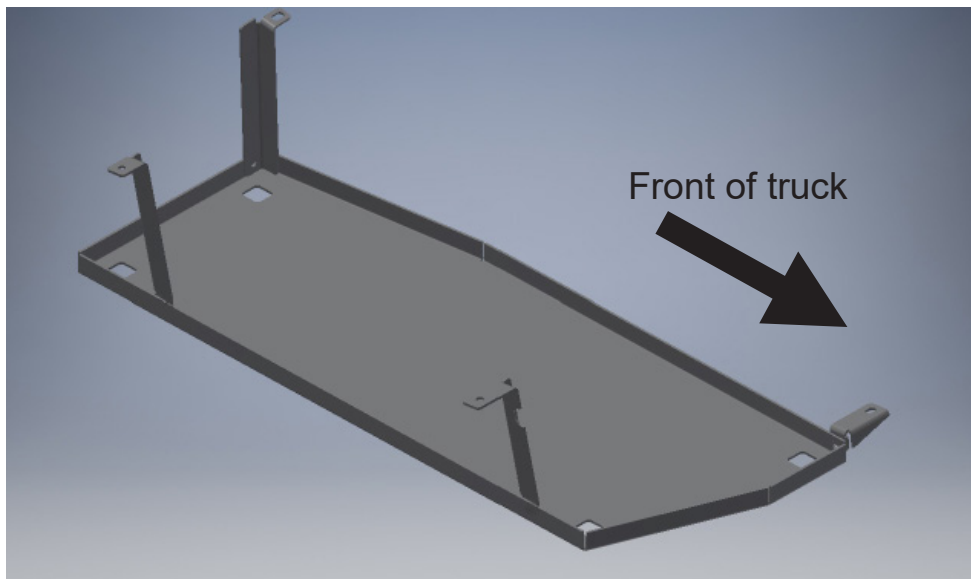

Note: The smallest of the four supplied brackets is located at the front driver side of the skid. The longer bracket with the semicircle cutout is located at the front passenger side of the skid. The two rear brackets are similar in size but their locations and orientations can be viewed in the photo above.

2. Now we will lift the skid into place to mark the 2 drilled holes. The 2 locations you will need to drill are both on the driver side and are shown in the photos below. Note: If you don't want to lift the skid twice, the holes can carefully be drilled through the skid while its in place.



3. Once the 2 holes are drilled, the skid can be loosely installed using the hex head hardware in the 2 locations where you drilled, and the button head hardware everywhere else. Ensure all hardware is loosely installed before tightening any bolts.

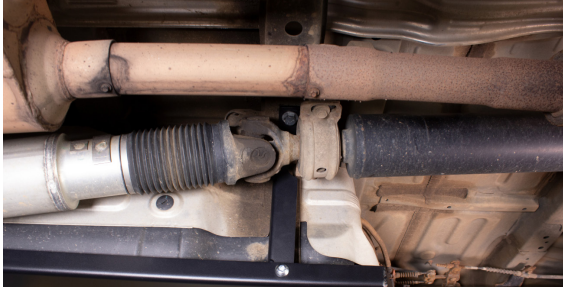

4. Once all of the hardware is started, go ahead and fully tighten it.
5. Enjoy your new gas tank skid!